

# Ryan Aeronautical Company Navion B "Super 260"

Introduced as the "Super 260" in March 1950, the B Model Navion was Ryan's final attempt at boosting the Navion's performance. The original E-185 Continental was replaced by a geared Lycoming of 260hp. The engine's increased length added three inches to the plane's length. Other changes included a strengthened airframe, a deluxe interior with improved cabin ventilation, updated avionics and access to the baggage compartment through a door on the left hand fuselage side.

Despite the boost in performance Navion sales were on the decline. In 1950 Ryan announced production of the Navion A would give way to the Navion B. Soon Ryan had to admit they were loosing money on every Navion they continued to build, and even though orders were still being placed, Ryan ceased production in May 1951 at serial number NAV-4-2350B (N5450K).

In 1958 the type certificate and production rights were sold to the Tubular Service and Engineering Co. in Houston, Texas. Rather than build new Navions, TUSCO offered the Models D (April 1958), E (May 1959) and F (September 1959) as conversions, installing a 240hp Continental O-470-P, 250hp IO-470-C or 260hp IO-470-H respectively.

### COLOR NOTES:

FOLLOWING ON WITH THE UTILITY 205 AND DE LUXE 205 LOGOS, THE SUPER 260 FEATURED AN ARROW SHAPED LOGO ON THE FUSELAGE SIDE, PROCEEDED BY THREE CHEVRONS. THE UTILITY 205, AS RYAN'S BASIC MODEL FEATURED ONE CHEVRON, WHILE THE UPGRADED DE LUXE 205 HAD TWO.

TWO PAINT SCHEMES WERE AVAILABLE IN 1950 AND 1951.

SCHEME ONE: OVERALL SUNSET MAROON WITH IVORY LOGOS AND REGISTRATIONS.

SCHEME TWO: GALA GREEN AND IVORY. REGISTRATIONS AND LOGOS IN THE OPPOSING COLOR.

SUNSET MAROON AND IVORY. REGISTRATIONS AND LOGOS IN THE OPPOSING COLOR.

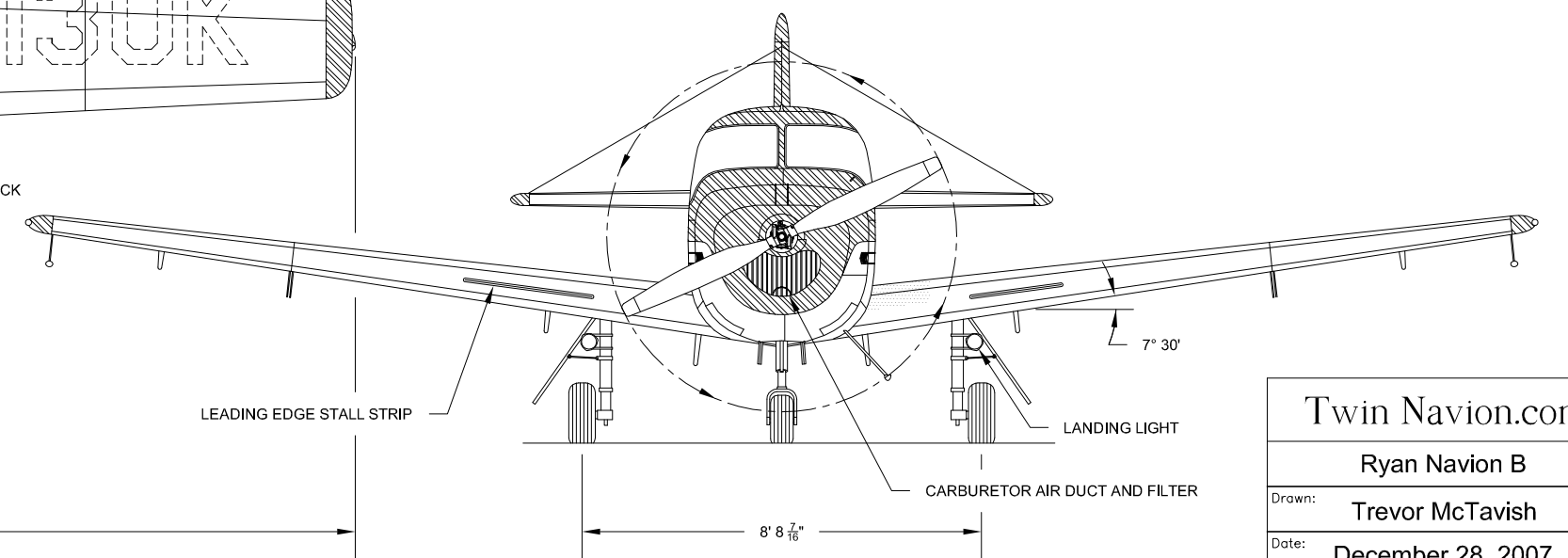
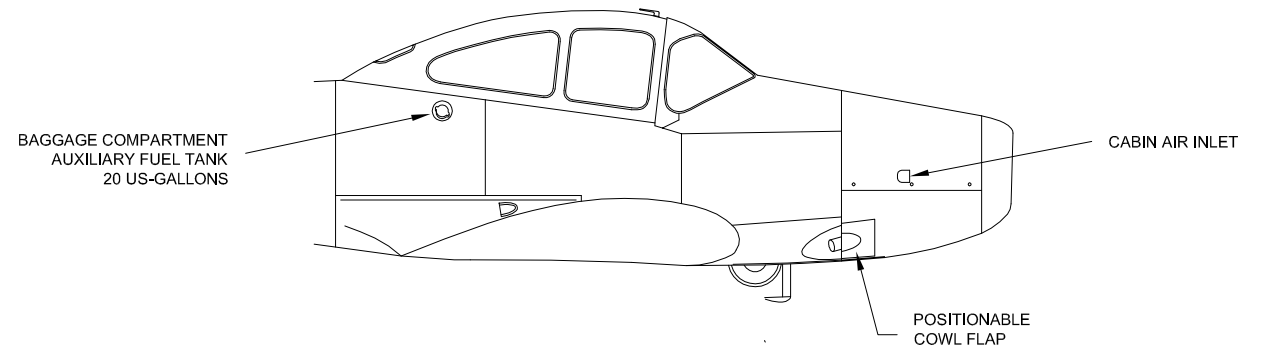
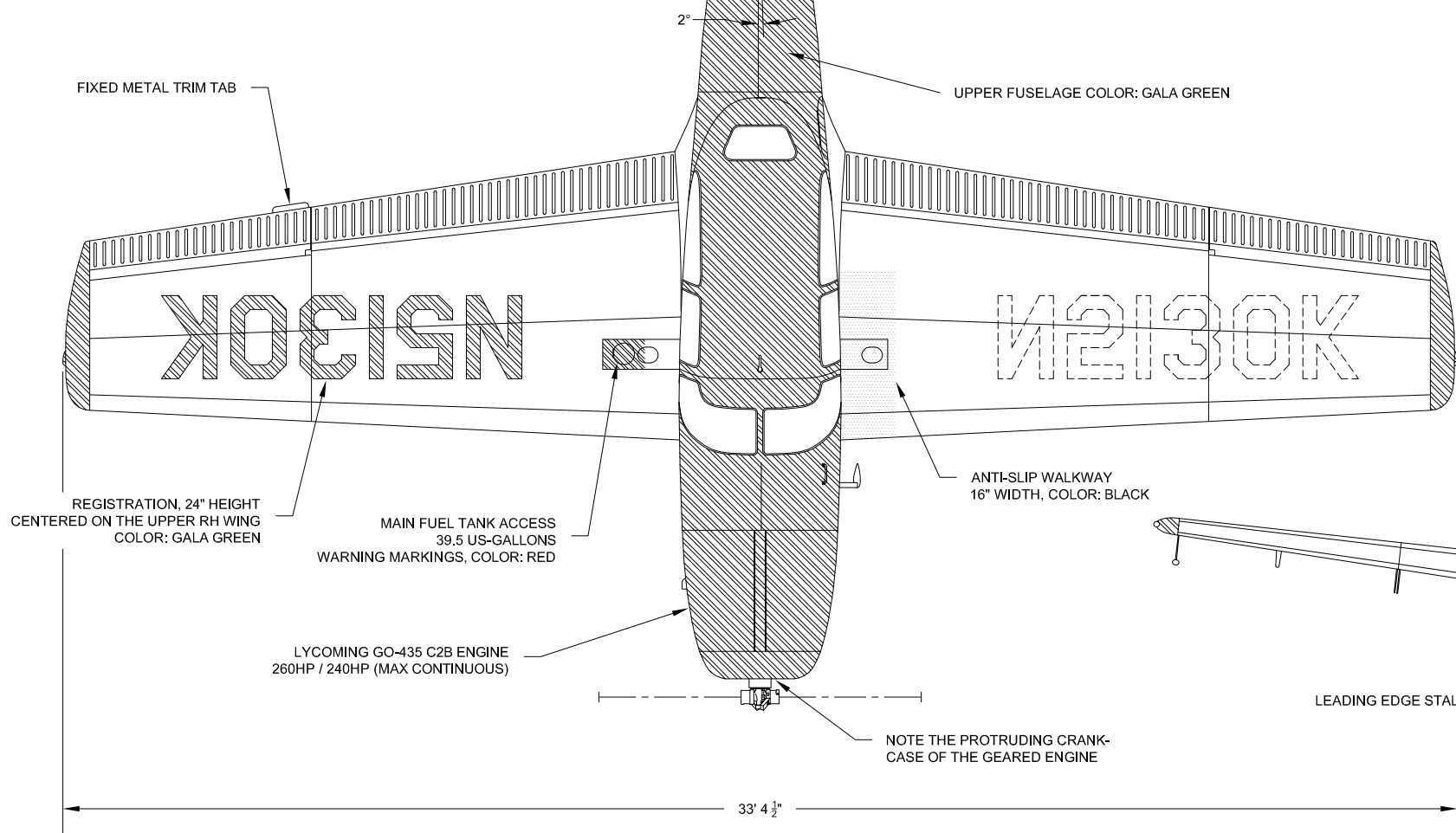
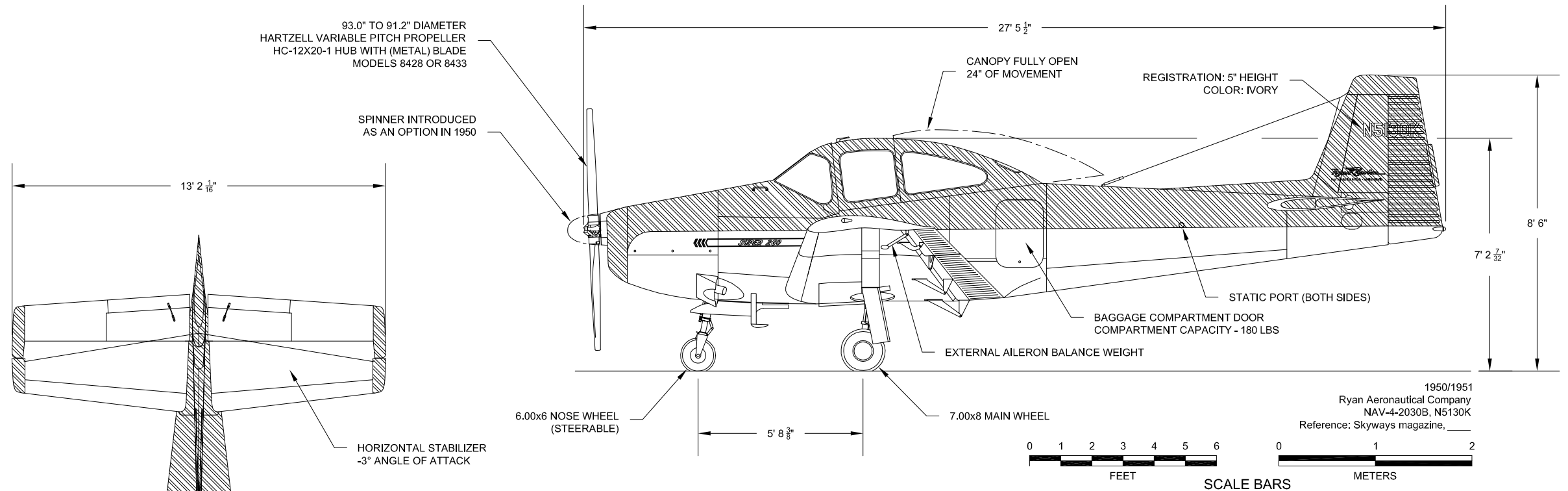

Twin Navion.com	
Ryan Navion B	
Drawn:	Trevor McTavish
Date:	December 28, 2007
Scale:	1/48
Sheet:	1/1